

# FREEMANTLE

13 Atkinson Way  
Foxhills Industrial Estate  
Scunthorpe  
North Lincolnshire  
United Kingdom  
DN15 8QW

T: +44 (0) 1724 276 908  
F: +44 (0) 1724 276 909  
E: sales@freemantle-uk.co.uk  
W: www.freemantle-uk.co.uk

**THE SUPERIOR**  
RANGE OF PACKAGING MACHINERY

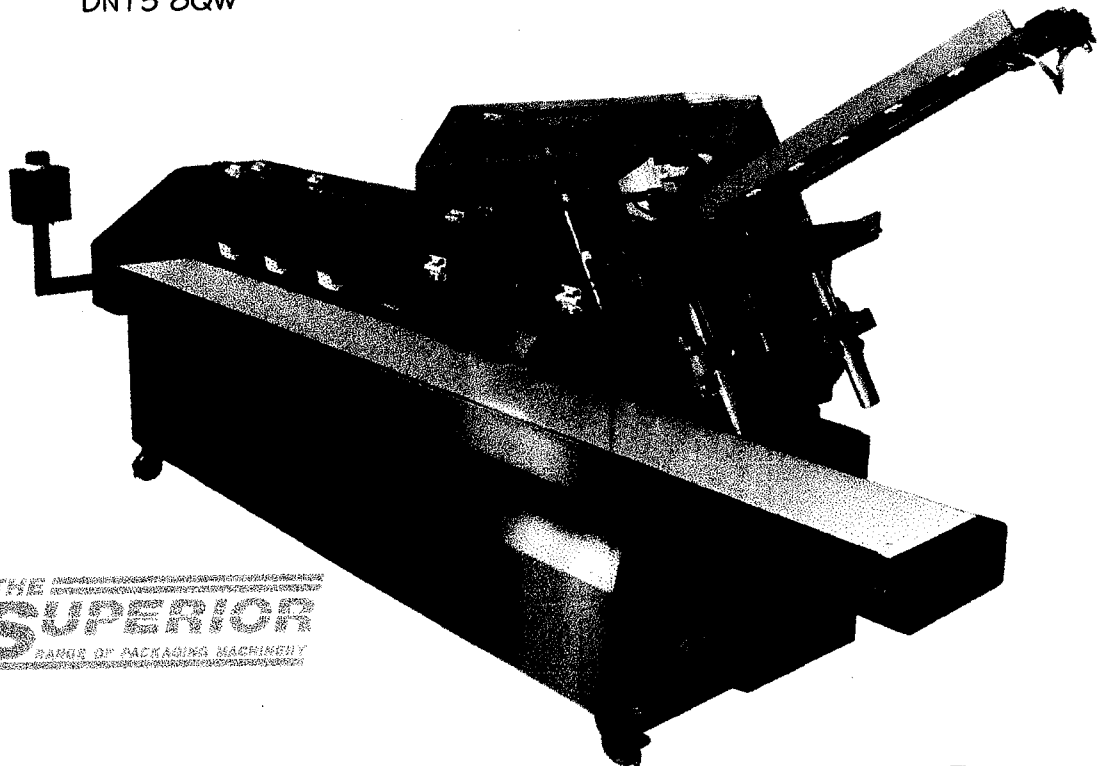

## SEMI AUTOMATIC PRE - GLUED SLEEVER (SII). OPERATIONS MANUAL.

MACHINE SERIAL NO:  
**02-155.**

# Declaration Of Conformity

**Manufacturers Name:**  
**Manufacturers Address:**

T. FREEMANTLE LTD.  
ATKINSON WAY,  
FOXHILLS IND. EST.  
SCUNTHORPE.  
NTH. LINCOLNSHIRE  
DN15 8QW.

**Type of Equipment:**

PREGLUED SLEEVER

**Equipment Class:**

PACKAGING MACHINERY

**Model Number:**

02-155

**Year of Manufacture:**

2003

**Applicable Council Directive(s) :**

89/391/EEC, 91/368/EEC, 89/336 EEC, 93/44/EEC, 91/269/EEC, 92/31/EEC, 72/73 EEC

**Standards to which Conformity is Declared:**

EN287 1 & 2 1991

Safety of machinery: Basic concepts, general principles for design.

EN290

Safety of machinery: Safety devices to prevent danger zones being reached by upper limbs.

EN418

Safety of machinery: Emergency stop equipment, functional aspects – principles.

EN60204-1 1994

Safety of machinery: Electrical equipment of machines.

EN 50081-2 1994

Generic Emissions Standard: Industrial installations.

In addition, this machine has been designed and manufactured in accordance with :

BS7671

IEE Wiring Regulations 16<sup>th</sup> Edition 1991

I the undersigned hereby declare that the equipment specified above conforms to the above Directive(s) and Standard(s).

Place: Scunthorpe, England

Signature:



Full Name: Mr Mel Wain

Date : APRIL 2003

Position: Engineering Supervisor

**SUPERIOR**  
**PRE - GLUED SLEEVER**  
**USER INSTRUCTION MANUAL**  
**READ THIS MANUAL CAREFULLY BEFORE OPERATION**

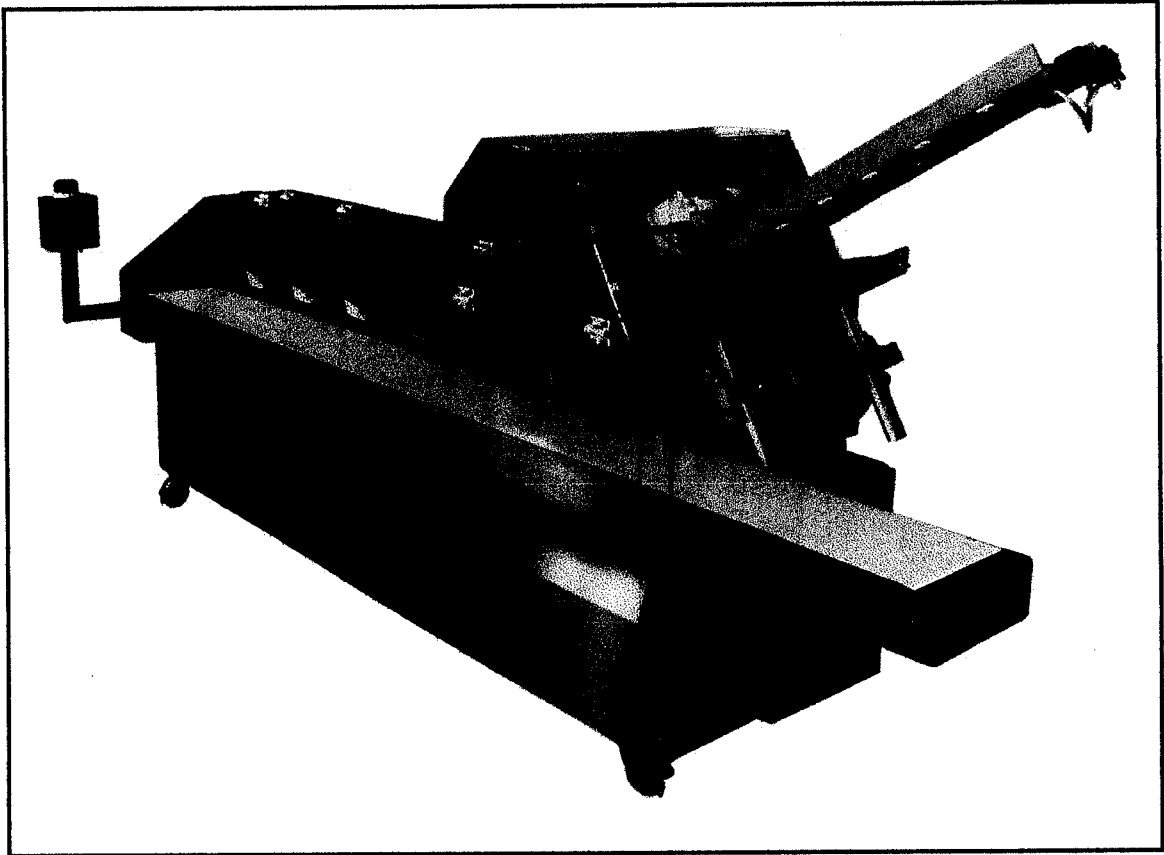

**STANDARD FEATURES**

- ROTARY CARTON FEED SYSTEM
- VARIABLE SPEED MACHINE CONTROL FROM OPERATORS CONTROL POD
- OVERLOAD PROTECTION ON MACHINE MAIN DRIVE
- DISCHARGE DRIVE BELTS
- LOW LEVEL MAGAZINE SLEEVE DETECTION
- AUTOMATIC CUT-OFF SWITCH, IF SLEEVE NOT FULLY LOADED

## CONTENTS

<b><u>Section 1: General Information</u></b>		<u>Page</u>
<b>A</b>	<b>Introduction / Safety</b>	
	1. Preface	6
	2. Legend	7
	3. Safety Instructions	
	a) General Information	7-8
	b) Operation	8
	c) Maintenance	8-9
	d) Cleaning	9
	e) Liability	10
<b>B</b>	<b>Technical Data</b>	
	1. Dimensions	11
	2. Output	11
	3. Format Range	11
	4. Machine Data / Requirements	12
	5. Sound Emission Data	13
<b>C</b>	<b>Description of Machine</b>	
	1. General Description	
	a) Machine Construction	14
	b) Machine Specification	14
	1. Identification	15
	2. Operating Panel (Pod)	15
	3. Machine Functions	16
	a) Product Infeed	17
	b) Product Loading	17
	c) Sleeve Discharge	18
<b>D</b>	<b>Installation and Connection</b>	19

## **Section 2: Operation**

### **A Initial Operation**

1. **Preparing Machine for Operation**
  - a) **Main Control Panel** 20
  - b) **Pre Production Check list** 20 - 22
1. **Quick Start Instructions** 22
2. **Operator Input** 23
3. **Housekeeping**
  - a) **Routine Cleaning** 23
  - b) **Sleeves** 23

### **B Trouble Shooting**

1. **Machine Will Not Run** 24
2. **Sleeve Erection** 24 - 25
3. **Vacuum Failure** 25
4. **Clutch Overload** 25 - 26

## **Section 3: Maintenance and Setting**

### **A Maintenance Schedule**

<b>1. Lubrication Schedule</b>	<b>27</b>
<b>2. Maintenance Schedule</b>	<b>28 - 29</b>
<b>3. Air pressure Regulator</b>	<b>29</b>
<b>4. Electrical System</b>	<b>30</b>

### **B Size Change**

<b>Note</b>	<b>31</b>
<b>1. Sleever Change</b>	<b>31 - 32</b>
<b>2. Rotary Sleeve Feed Change</b>	<b>32 - 35</b>

# **SECTION 1**

## **A INTRODUCTION / SAFETY**

### **1.A.1 Preface**

This instruction manual is directed to personnel who operate and maintain the Superior machine. This manual should not be regarded as a substitute for a thorough instruction in the installation and operation of the machine.

We recommend that your operating personnel participate in the instruction and training programs provided by T. Freemantle's highly skilled service personnel. This service is normally available during installation and commissioning.

This manual is meant to help you during your daily work on the machine and during maintenance, which must be carried out regularly.







**All personnel involved in the installation, set-up, operation, maintenance and/or repair of this machine must thoroughly read and fully understand this instruction manual.**

If you should have any questions, please contact T. Freemantle Ltd. The manual is to be stored in a place near to the machine and must be easily accessible for the operator.

Please operate your Superior machine in accordance with the instructions given in this manual. This will guarantee efficient operation and a high availability of your machine.

## 1.A.2 Legend

	and <b>bold type</b>	=	take special note
	and <i>italics</i>	=	refers to another passage in the document
	and 	=	warning of danger to health
!	and 	=	warning of damage to equipment

## 1.A.3 Safety

### a) General Information

The Superior machine has been designed and constructed to meet a high technical standard and is therefore safe and reliable in operation.

Nevertheless the machine can become dangerous

- ◇ If operated improperly by personnel not trained and instructed thoroughly.
- ◇ If the instructions given in this operation and maintenance manual are not strictly observed.

We specifically point out that you should only

- ◇ Operate
- ◇ Service
- ◇ Maintain
- ◇ Supervise

The Superior machine if you have been trained and instructed to do so.

The machine must only be operated with all safety devices in their proper location and in their operating order. A Safety Interlock System is fitted to all opening guards, operating at 24 V, inhibiting machine operation if guards are opened.

No modifications must be made to the machine without prior permission of T. Freemantle Ltd.

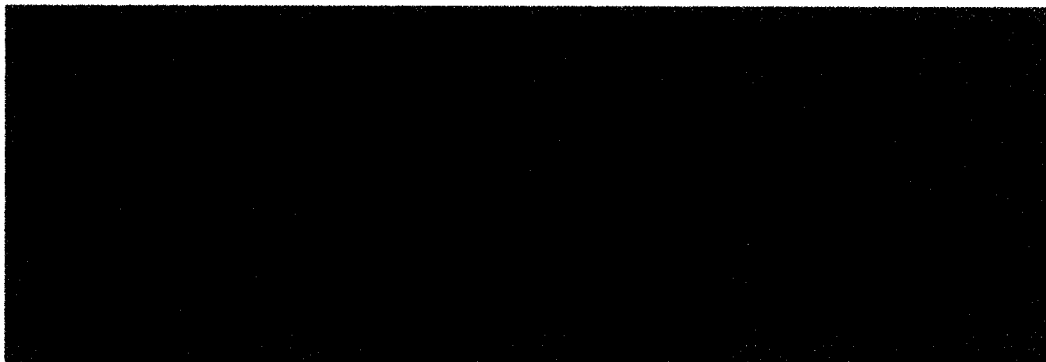

**b) Operation**

Persons must only operate the Superior machines

- ◇ Who have been properly trained and instructed in their use.
- ◇ Who will perform their duty in reliable manner.

It is incumbent upon the company operating the machine to ensure that the instructions given in this manual are strictly followed. Where necessary the company is to issue supplementary instructions.

**c) Maintenance**

Do not perform any work on the machine while it is in operation. If this should be necessary, however, for example during

- ◇ Installation
- ◇ Maintenance
- ◇ Elimination of faults

Operate the machine or parts of the machine utilising the Jog facility.

Set up a precise working plan if several persons work on the machine at the same time. Appoint a person who will be responsible

- ◇ For coordinating the work to be done
- ◇ That safety instructions are strictly followed



The operating procedures applied must be appropriate to the technical possibilities of the Superior machine.

Safety and protection devices must not be changed or rendered ineffective.

Check the safety devices on the machine

- ◇ At least once a week
- ◇ After rebuilding the machine
- ◇ After major maintenance or repair work
- ◇ After replacing or repairing safety devices

**d) Cleaning**

The Superior machine is designed to be safe to construct, install, operate and maintain, consistent with current legislation. Consideration has been given to the ergonomics of machinery use, i.e. to achieve the most effective safe performance of the machinery and its operator.

The Superior machine is manufactured from only corrosion-resistant (corrosion-resistant coated) materials that can be cleaned over and over. All electrical wiring is to I.P. 54, BS 2771 (part .1) and EN60204 (part .1) standard.

Included in this machine manual are instructions for safe starting up, installation, adjustment, maintenance, training and hints for safe and efficient day-to-day operator input.

T. FREEMANTLE LTD have ensured, so far as is reasonably practicable, that the machinery is so designed and constructed that it will be safe and without risks to health and safety at all times when it is being set, used, cleaned or maintained.

All guarding (fixed or otherwise) should not be removed before or during operation of the machinery. All accessible parts of the machine are guarded (sliding doors or hinged guards) and are electronically safety interlocked. The safety interlock circuit must not be bypassed or overridden.

<b>ROUTINE CLEANING PROCEDURE</b>	
Daily	Thoroughly clean the machine to remove any build up of dust and products.
Conveyor Chains, Flights etc.	Use a soft brush and clean to remove dust, carton fragments etc.
Infeed Conveyor	Wipe over loading table to remove any product and debris
Machine Guards	Wipe over with stainless steel cleaner and soft cloth

**e) Liability**

You are not allowed to make any changes to the machine without the permission of T. Freemantle Ltd. This includes

- ◇ Rebuilding machines, mounting and dismounting parts supplied by other manufacturers.
- ◇ Rendering ineffective or removing safety devices.

Any unauthorized modification made on the machine will invalidate the manufacturers liability.

**Failure to observe the safety regulations may:**

- ◇ Cause danger to the health of the user or to a third party
- ◇ Cause damage to the equipment or other equipment
- ◇ Impair the machine's efficiency

# SECTION 1

## TECHNICAL DATA

### B

#### 1.B.1 Dimensions

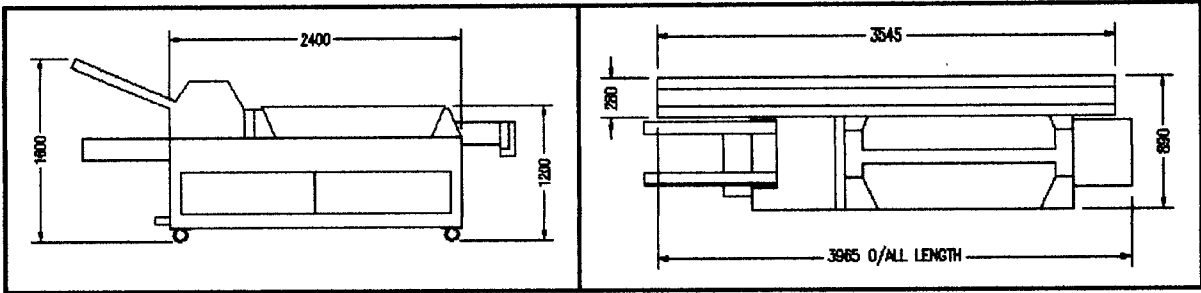

#### 1.B.2 Output

Fully variable from 20 to 80 sleeves per minute, subject to machine bucket pitch and size and quality of the sleeves.

#### 1.B.3 Format Range

The Pre – Glued Sleever has a size range as follows, subject to machine pitch and certain restrictions on combinations of sizes.

##### 12" Pitch

Length	50/250mm – min/max
Height	25/100mm – min/max
Width	70/300mm – min/max

It should be noted that there are restrictions on certain combinations of sizes. The size range of the machine is also dependant on the Infeed system employed. Additional sizes that are not accommodated in the standard range can be catered for subject to modification.

The wide range of sleeves that the Pre – Glued Sleever runs includes full, bands and watch strap sleeves.

## 1.B.4 Machine Data / Requirements

Compressed Air	80 psi / 5.5 bar
Electrical Power Supply	240v 50Hz
AC Inverter Variable Speed	1.1 Kw
Infeed Belt Motor (If Fitted)	0.37 kW (0.5 HP) AC Motor. Variable Speed gearbox.
AC Inverter Variable Speed	1.1 Kw
Infeed Belt Motor (If Fitted)	0.37 kW AC Motor.
Outfeed Belt Motor (If Fitted)	0.18 kW AC Motor.
Main Drive Motor	0.75 kW AC Motor
Total Electrical Load	2 kW - Standard Machine

## 1.B.5 Sound Emission Data

The following illustration shows the decibel noise emission reading from the Superior machine while the machine is in normal continuous production running.

The areas of probable operator input are highlighted on the drawing below, as the Superior machine is a semi-automatic unit there is one defined workstation.

The readings are taken from a point 1 metre from the surface of the machine and 1.6 metres from the floor and are measured in decibels (dB).

(Fig. 01)

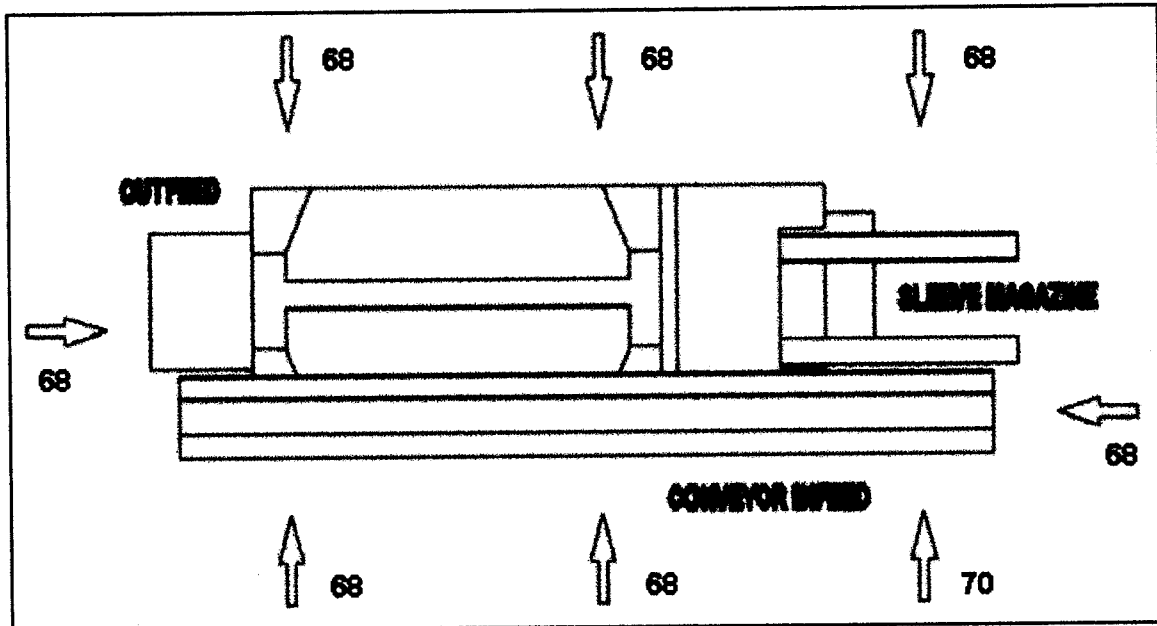

Fig.1

# SECTION 1

## C DESCRIPTION OF MACHINE

### 1.C.1 General Description

#### a) Machine Construction

Construction	Rigid Stainless Steel one-piece frame with Stainless Steel and Aluminium Construction. Comprising of Stainless Steel or corrosion resistant coated Shafts, Sprockets, Transmission Drives and Chains as standard unless otherwise stated.
Shafts	Sealed for life Ballraces on all main shafts.
Mobility	Fully mobile on Lockable Castors (Optional Adjustable Jacking Feet).
Guarding	Brush Finish Stainless Steel Guarding, with Polycarbonate / Acrylic viewing stations.

#### b) Machine Specification

Product Conveyor (Standard Machine)	Belt Conveyor. 3.5mtr x 300mm Standard machine.
Machine Speed Control	Variable- from operators control pod. Base speed set from main control panel.
Safety Interlock	Full Safety Interlock Guard System- 24V.
Main Drive Protection	Mechanical, Clutch and Electrical Overload Protection on Machine Main Drive.
Discharge Drive Belts	Accelerate sleeves efficiently away from path of moving buckets.
Low Level Magazine Sleeve Detection	Linked to warning beacon on Pod.
Automatic Cut-off Switch	Operates if product is not fully loaded.
Change Size Assistance	Digital Readouts to Assist Change Size and Pinlocks
Rotary Sleeve Feed System	Twin Rotary Sleeve Erector for positive erection and placing of sleeve.

### 1.C.2 Machine Identification

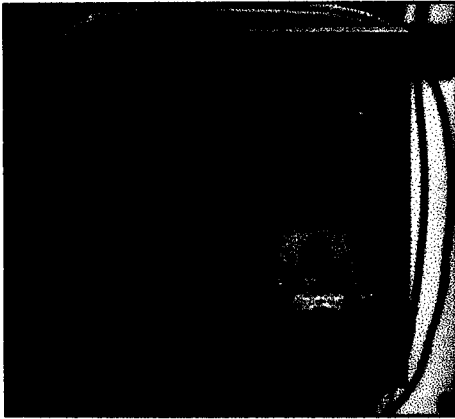

Fig. 2

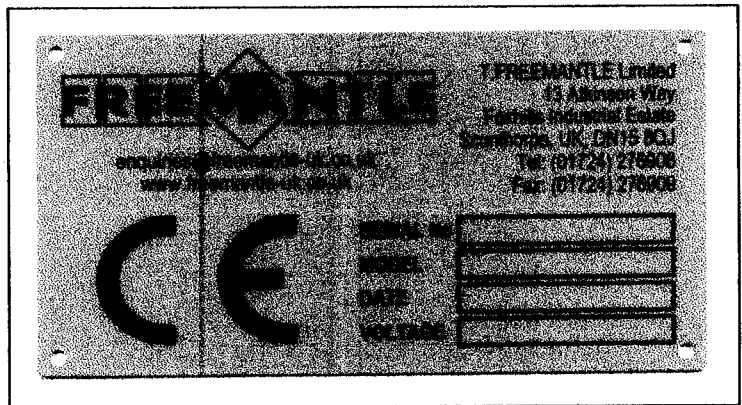

Fig. 3

The CE identification plate is located on the bottom left face of the Main Electrical Panel (Fig. 2/3).

**Always quote the information on this plate when making technical enquiries.**

### 1.C.3 Operating Panel (Pod)

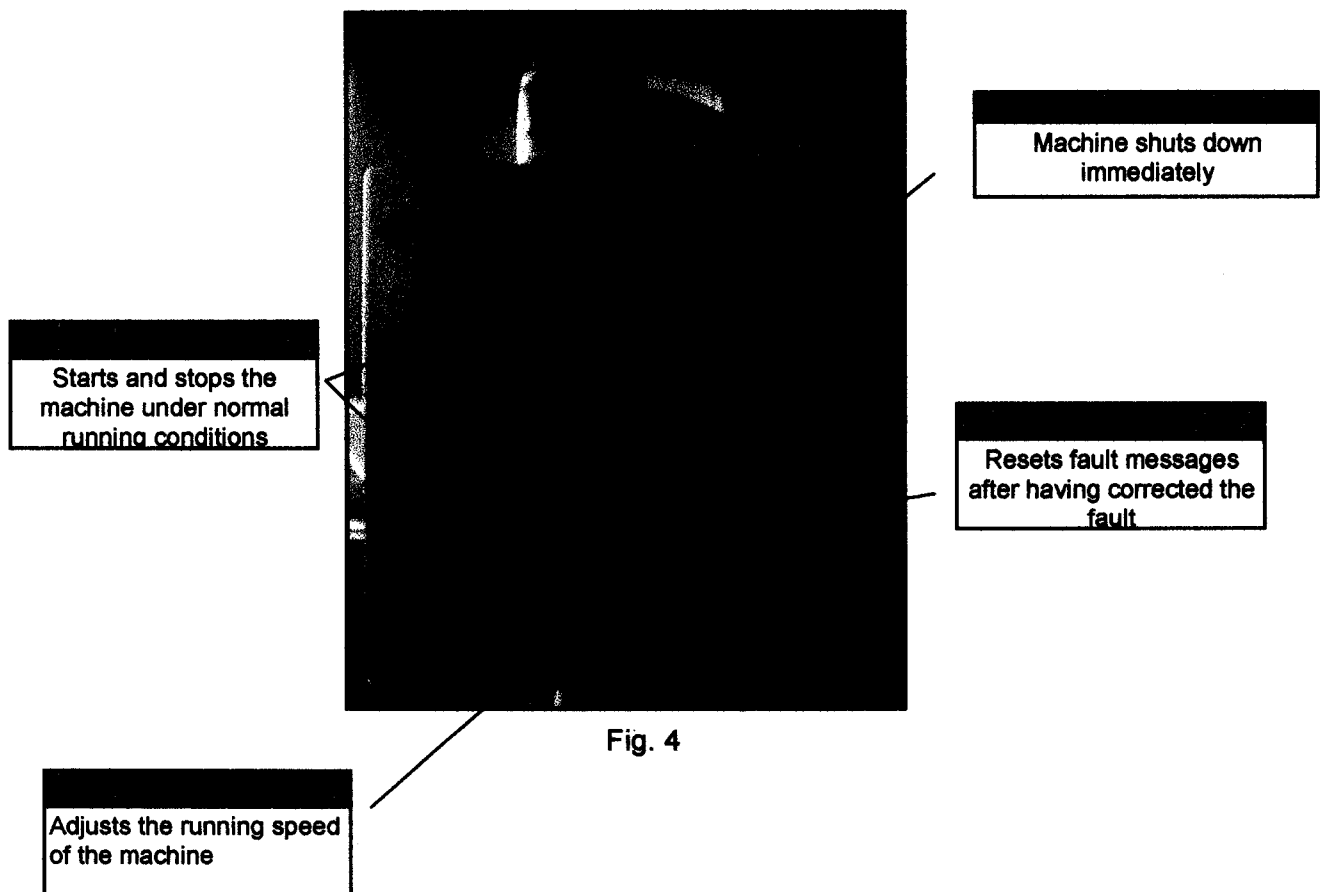

Fig. 4

## 1.C.4 Machine Functions

Sleeve blanks are drawn from the angled magazine by a standard twin arm Rotary Sleeve Feeder and are automatically erected into continuously moving bucket chains. The bucket chains feed the erected sleeves towards the operator or loading conveyor. As the sleeves are moving the load side automatically gives full access for loading. On the opposite side of the machine, the sleeve back assembly avoids the product being pushed straight through the sleeve.

The product is then delivered to the erected sleeve on the product infeed conveyor side and is manually loaded into opened sleeves. After loading, the sleeve tabs are automatically tucked if fitted, then discharged is driven by side belts (Fig. 5).

### Semi Automatic Pre - Glued Sleever

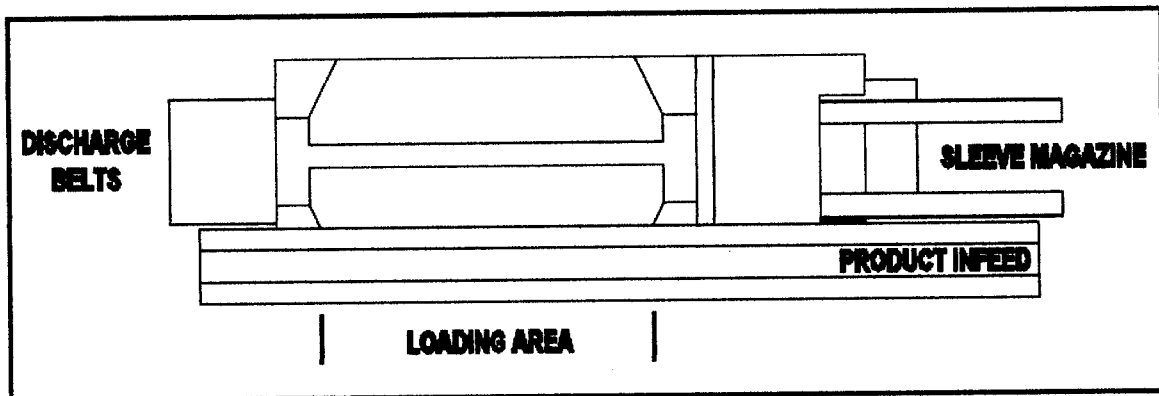

Fig. 5

### 1.C.4. a) Product Infeed

Product is loaded into the infeed conveyor, which carries the product. The operator inserts the product into the pre-opened sleeve. (Fig. 6)

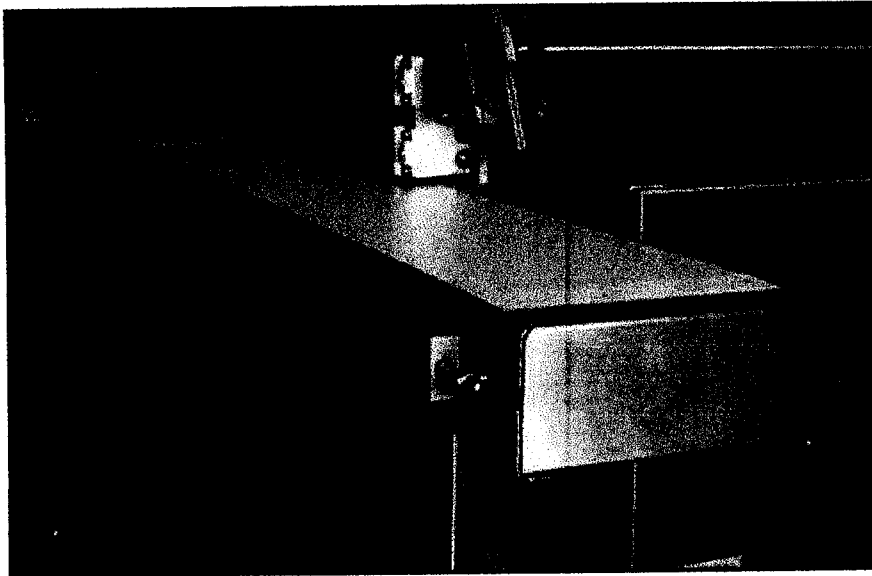

Fig. 6

### 1.C.4. b) Product Loading

The operator pushes the product from the infeed conveyor across the loading table and into the pre-opened sleeve. The loading table is designed to bridge the product between the product infeed conveyor and the sleeve mouth and also to condition the product for loading into the sleeve. It ensures smooth transfer of the product between the conveyor and the sleeve. (Fig. 7)

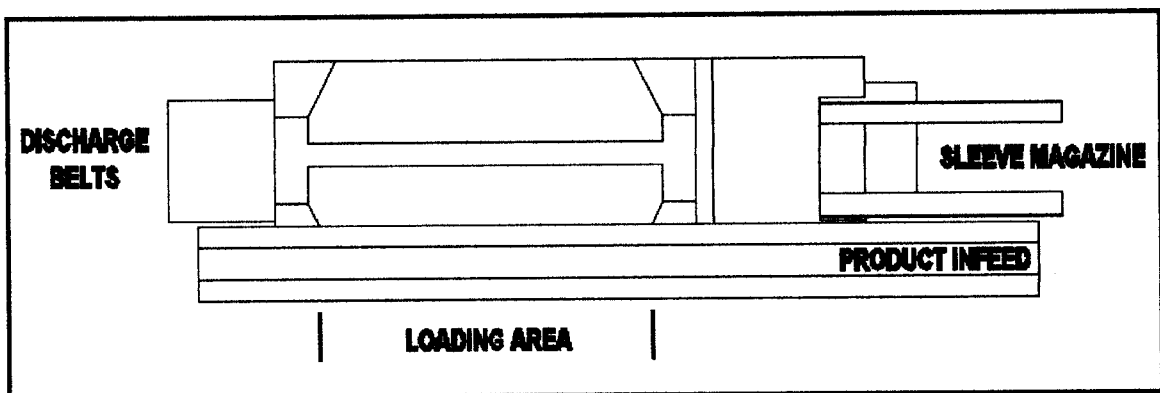

Fig. 7

### 1.C.4. c) Sleeve Discharge

The sleeves are discharged via the outfeed belt transfer system. The sleeves travel down through the machine positioned in the buckets as the bucket starts to rotate around the sprocket on the idler end of the bucket conveyor located at the end of the machine. The belts run continuously pulling the sleeves clear of rotating buckets. The sleeves then accelerates out through the belt transfer system. (Fig 08 and 09)



Fig 08

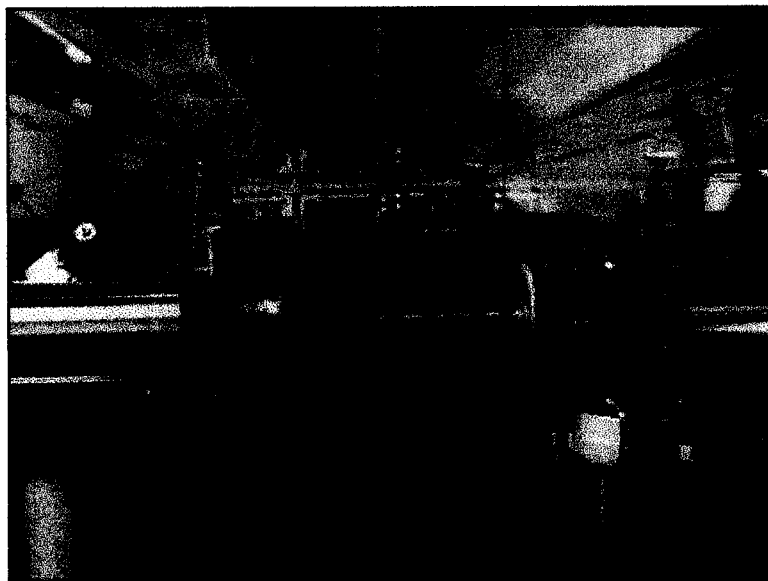

Fig 09

# **SECTION 1**

## **D** **INSTALLATION AND CONNECTION**

### **Transportation**

The SUPERIOR machines have been designed and manufactured around a rigid stainless steel one-piece frame to give the machines excellent stability and maximum strength. For transportation purposes the machines are generally shipped in one piece. In special circumstances the machines may be shipped with guarding and control pod / panels removed to avoid damage. In the event of the machine needing any components to be removed for shipment then machinery is supplied with information outlining any re-assembly instruction that may be needed.

### **Installation**

The SUPERIOR machines have a guarantee of 12 month from date of installation; this guarantee is only applicable if a qualified T. Freemantle engineer installs the machinery.



*Allocation should be made for connection to the correct power and compressed air services. (See Machine Data Section 1.B.4)*

## SECTION 2

### A                      INITIAL OPERATION

#### 2.A.1      Preparing Machine for Operation

**a) MAIN CONTROL PANEL**

Standard Position	Situated at the Rotary end of the machine.
-------------------	--

**b) PRE-PRODUCTION CHECK LIST**

Electrical Power	Turn Mains Isolator on Control Cabinet to 'ON' position (Fig. 10)
------------------	---

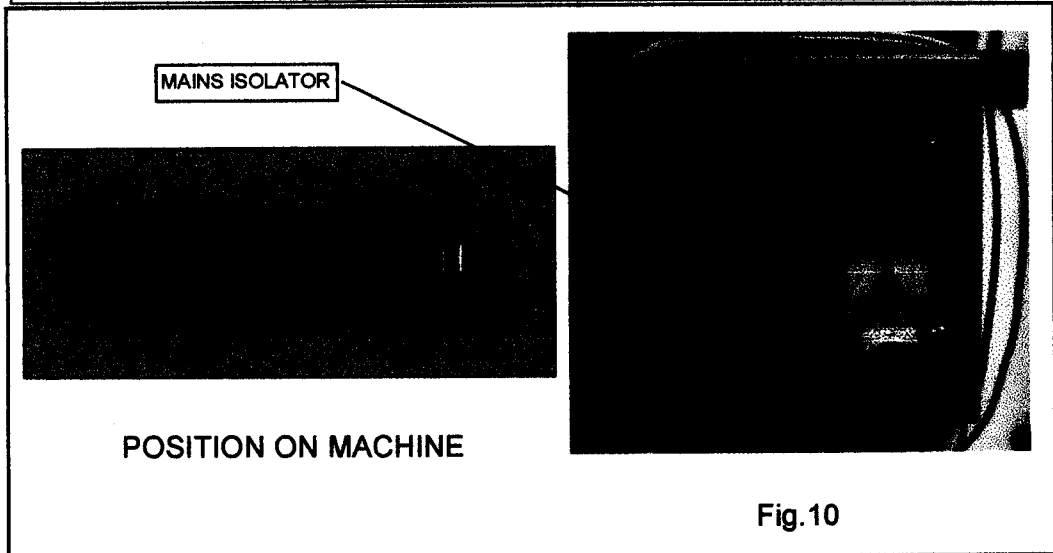

Bucket Conveyor	Check that it is empty.
Infeed Conveyor	Check that it is empty.

**b) PRE-PRODUCTION CHECK LIST CONTINUED**

Sleeve Magazine	Check that it is loaded and that the sleeves are placed in correctly. (Fig. 11)
-----------------	---

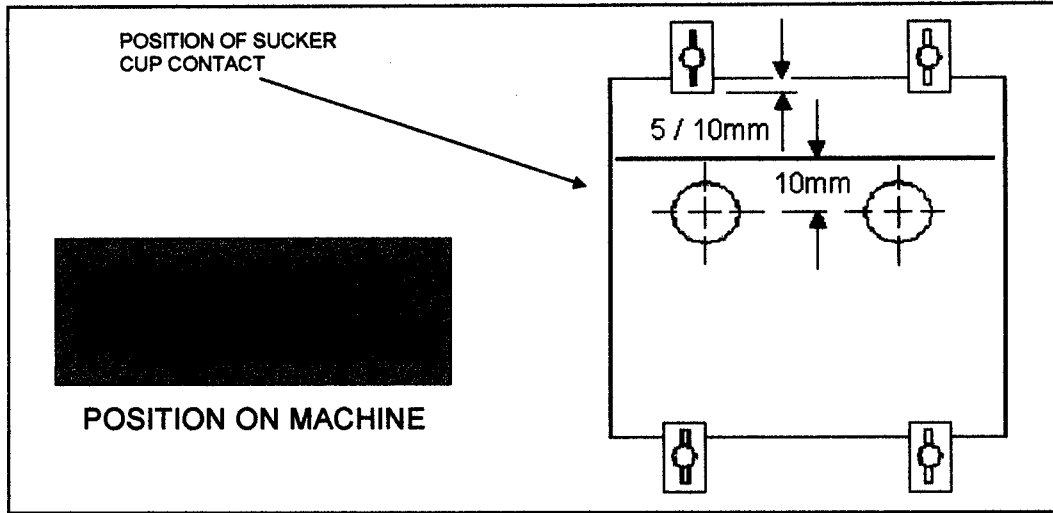

Fig. 11

Emergency Stop Buttons	Check that these are released (Fig.12).
------------------------	---

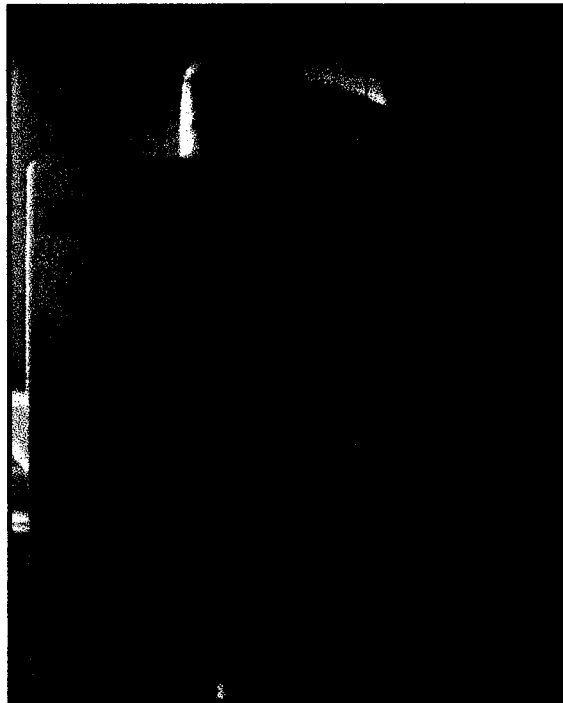
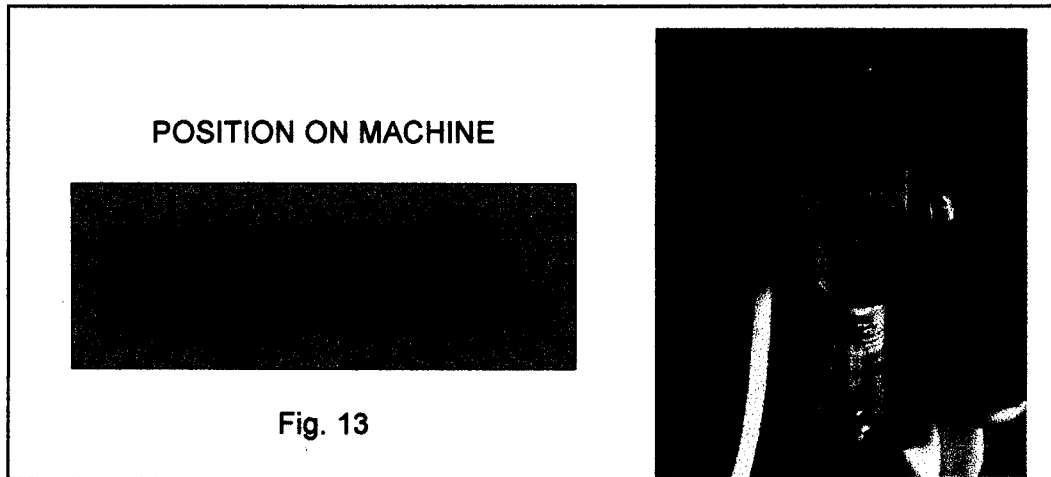

Fig. 12

**b) PRE-PRODUCTION CHECK LIST CONTINUED**

Machine Air Supply	Check that the Air Supply is set to the correct level on the Air Regulator Gauge, Normal 80 psi. (Fig. 13)
--------------------	--



Guarding	Check that these are closed.
Vacuum Pump	The vacuum pump power's on and off automatically from the footswitch
Reset Safety Switch	Ensure the Reset Push Button lamp lights when pressed.
Start Machine	Press the 'Green Run' Push Button, machine speed can be adjusted by operation of the 'Speed Control Potentiometer.

**2.A.2 Quick Start Instructions**

SUPERIOR OPERATING PROCEDURE	
1	Turn on the Main Isolator on the front of the Main Control Panel.
2	Check that the compressed air is switched on and at the correct pressure.
3	Close all guards and reset all emergency stop buttons.
4	Check that the sleeve magazine is full.
5	Check that the 'Remote Lead' is NOT plugged into the main control panel. (if provided)
6	<p><b>RUN-</b> Press the "Machine Start". The machine now ramps up to its preset speed.</p> <p>Turning the "Speed Control" Pot on the Pod adjusts the machine speed accordingly.</p>

## **2.A.3      Operator Input**

Sleeve magazine	Operators will need to refill the sleeve magazine periodically during production.
Product infeed	Loading of the product into the sleeve is normally undertaken manually to hand feed the product from infeed and into the sleeve.
Product discharge	Product is normally taken from the machine automatically and moved on through metal detectors, check weighers etc. Operator input may be required in the event of a product back up.

## **2.A.4      Housekeeping**

### **Routine Cleaning Procedure**

General	Thoroughly clean the machine daily to remove any build up of dust and product.
Conveyor Chains	Use a soft brush and clean to remove dust, sleeve fragments etc.
Infeed Conveyor	Wipe over infeed conveyor to remove any product and debris.
Machine Guards	Wipe over with stainless steel cleaner and soft cloth.
Outfeed Belts	Remove any Product debris
Sleeve Guides	Remove any debris from the sleeve guides.

### **Sleeves**

Sleeve manufacturers advise that sleeves have a shelf life of around three months, providing they are stored away from moisture at temperatures of around 10 / 20 degrees C. If they are stored at varying temperatures or are allowed to become damp, then the shelf life will be reduced considerably, affecting all creases and therefore seriously reducing the production efficiency of the machine.

When the sleeves are stored in cases attention must be given to the number of cases on a stack. If too many cases are stacked together then this may cause the bottom cases to be crushed.

Bent, twisted or damp sleeves will cause problems during machine operation.

## SECTION 2

### B                      TROUBLESHOOTING

#### 2.B.1      Machine Will Not Run

Power Failure	Check that the Emergency Stop buttons are released. Check all guards are closed. Check the mains isolator is 'ON'. Check circuit breakers and main fuses.
Insufficient Air Pressure	Check Air Pressure Regulator Gauge.
Motor Overload	Reset thermal overload on the Inverter. See attached inverter manual.
Safety Interlock Circuit	Check all guards are closed.
Clutch Disengaged	1. Remove product-causing jam. 2. Manually turn the machine until the clutch re-engages. 3. When the clutch resets continue with normal operation.

#### 2.B.2      Sleeves Erection

Rotary Feeder Incorrectly Set	Check and adjust the settings if necessary.
Sucker cups Incorrectly Set	Check and adjust the sucker cups.
Sleeves too Tight in Magazine	Check and adjust magazine sides and ledges.
Loss of Vacuum	Check that the sucker cups are not damaged and that there are not leaks in the vacuum system. When a sleeve is selected the vacuum gauge should read 0.8 or less.
Sleeve Quality	Check if poor, bent, damp, and contact the supplier.
Sleeves not Erecting in Buckets	Check timing of Rotary Sleeve Feeder to Bucket Chain (Fig. 14) Check vacuum valve timing is correct (Fig. 15)

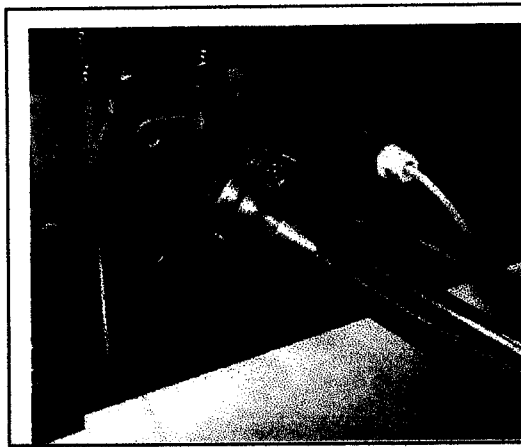

Fig.14

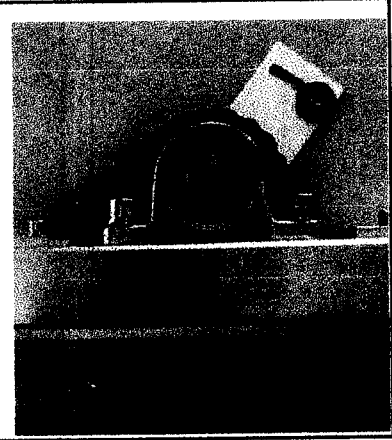

Fig. 15

### **2.B.3 Vacuum Failure**

Micro-switches	Check with a qualified Electrician.
Solenoid Valve	Check if blocked or sticking and clean / replace accordingly.
Pipework	Clear / repair pipes and vacuum circuit. (See Section 4 Circuit Diagrams)
Pump (Venturi)	Check vacuum pump filters. (See Section 3.A.4 Maintenance) Revise air flow in venturi to aid cleaning.
Suction Cups	Replace damaged as necessary
Insufficient Vacuum	Check gauge. Adjust regulating valve. Clean pump / replace cartridge.

### **2.B.6 Clutch Overload**

Contamination on Chains	Check for deposits within the chain that have been passed on behind the chain runners. In this event, spray penetrating oil within the chain runners. Leave to soak for approximately 20-30 minutes. Reset the torque limiter and start the machine. (See section 2.B.1)
Product Jam	Check thoroughly throughout the machine and clear as necessary. Reset the torque limiter (Fig. 16) and start the machine. (See Page 24 Section 2.B.1)
Sleeve Jam	Check thoroughly throughout the machine and clear as necessary. Reset the torque limiter and start the machine. (See Page 24 Section 2.B.1)
Misalignment of settings	Check the setting and adjust as necessary.

## **2.B.6    Clutch Overload Continued**

**Hint! Following a jam remove product or sleeves, which may be on the guards under the machine to prevent the machine picking up the discarded waste on restart.**

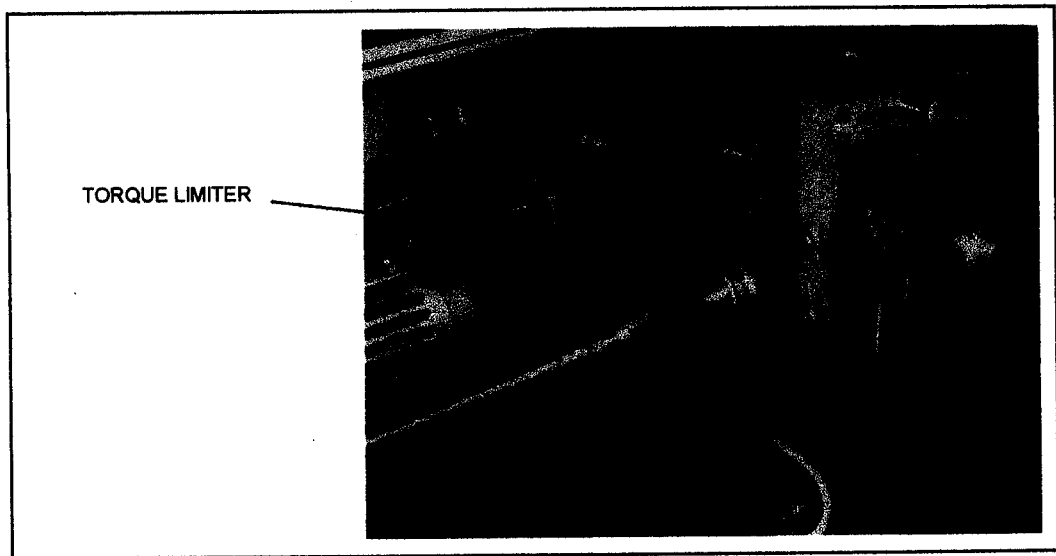

Fig. 16

## SECTION 3

### A      MAINTENANCE SCHEDULE



**N.B. ALL ELECTRICAL SWITCHES AND RELAYS HAVE A LIFETIME OPERATION OF 500,000 OPERATIONS AND SHOULD BE CHECKED PERIODICALLY**



**WE RECOMMEND THAT OUR SERVICE ENGINEERS COMPLETE AN ANNUAL SERVICE. FOR FURTHER DETAILS PLEASE CONTACT OUR SERVICE DEPARTMENT**

#### 3.A.1.      Lubrication Schedule

Main Drive Gearbox	Sealed box, follow manufactures instructions.
Chains	Lightly oil as necessary.
Rack Shafts	Lightly grease as necessary.
Lead Screws	Lightly grease as necessary.
Bearings	All bearings are sealed for life and will require no lubrication.
<b>Note!</b> Any parts of machinery that come into contact with the product should be lubricated with mineral based oils due to Product contamination; use 'Whitechain and Drive' or 'Food Lube' - spray when required.	

### **3.A.2. Maintenance Schedule**

<p>Daily</p>	<p>Clean machine thoroughly by removing build up of dust or product. It is essential that this schedule be maintained to ensure that the machine continues to run smoothly. (See Routine Cleaning Schedule Section 2.A.3)</p> <p>Check the water separator on the air pressure regulator unit and drain the unit accordingly.</p> <p>Check air pressure and maintain the compressors under their own schedule.</p>
<p>Weekly</p>	<p>Check machine thoroughly for efficient operation and security of components.</p> <p>Check vacuum suction cups for wear and tear so as to ensure accurate sleeve pick off.</p> <p>Check vacuum pipework for leaks.</p>

<p>Monthly</p>	<p>Product Infeed Tension, Remove the outer machine cladding and then tighten the tensioners as required. Ensure that the tensioners are given the same amount of tension on each side of the machine. Care should be taken not to over tighten the belt as this will induce excessive stretch (Fig. 17).</p> <p><b>Note!</b> Ensure that any guarding that has been removed is replaced before the machine is put back into production.</p>
----------------	--

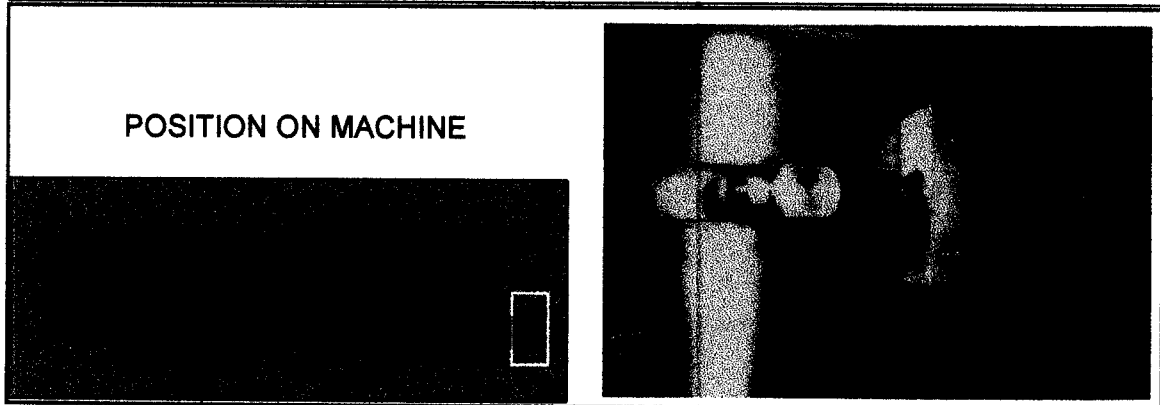

Fig. 17

**Monthly Continued**

Vacuum Pump	Clean and check the vacuum pump line filter if it is damaged replace with new.
Sleeve Bucket Chain	Check bucket conveyor chain tension and adjust as necessary by evenly tightening the two nuts in a clockwise direction. (Fig 18).
	Check for wear and stretch on all chain links.

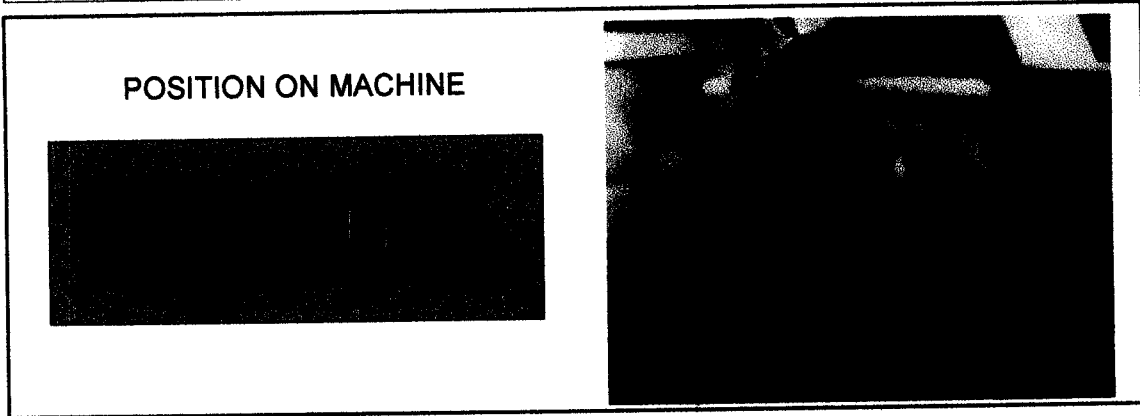

Fig. 18

Machine Drives	Check all tensioners throughout the machine and tighten as required. Note! Care must be taken not to overtighten the tensioners, as this will induce excessive stretch on the chains. Ensure that any guarding that has been removed is replaced before the machine is put back into production.
Annually	Check all bearings for wear. All bearings are sealed for life and should require no lubrication.

**3.A.3. Maintenance of the Air Pressure Regulator**

CHECK	Pressure gauge to ensure that the required operating pressure is correct
CHECK	Pneumatic hoses, unions and connections are all secure and free from leaks

### 3.A.5. Maintenance for the Electrical System



**N.B. WE RECOMMEND THAT THE ELECTRICAL SYSTEM SHOULD BE CHECKED ON A REGULAR BASIS BY A QUALIFIED ELECTRICIAN**

<b>CHECK</b>	That wiring and all electrically operated components are secure, undamaged and correctly enclosed Remake any damaged or defective wiring connections and replace any damaged components
<b>CLEAN</b>	Interior of control cabinet, taking care not to damage any item (Fig.19)
<b>CHECK</b>	Correct operation of safety guard interlocks
<b>CHECK</b>	To prevent water ingress due to cleaning

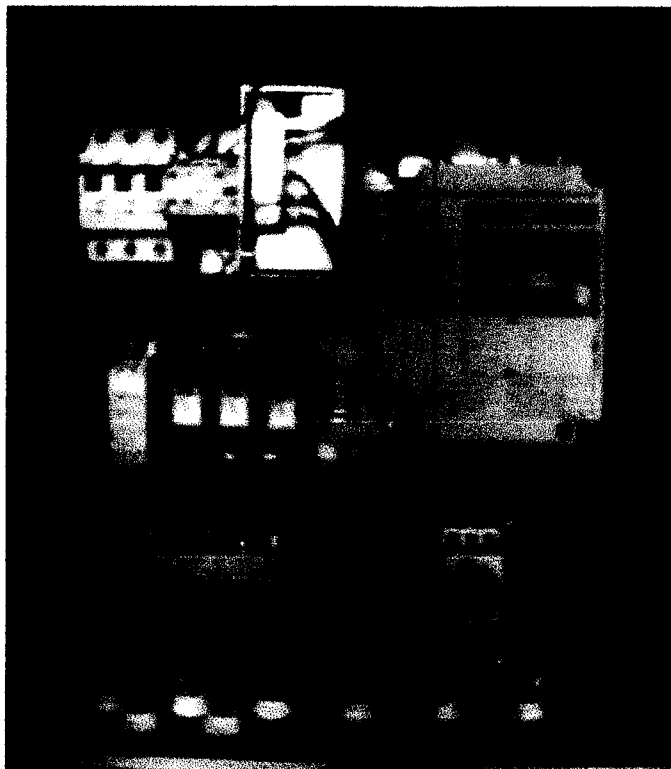

Fig. 19

# SECTION 3

## B

## SIZE CHANGE

### 3.B.1. Sleever Change Procedures

<p>For Height of Sleeve</p>	<p>Adjustment is obtained on the two overhead rails, by first loosening the locking screw. Then turning the hand wheel to the required pinlock setting or readout on the digital indicator. (Fig. 20) As a guideline the overhead rail should be positioned so as the sleeve can travel freely through the machine.  <b>Note!</b> See attached Pinlock Sheet.</p>
-----------------------------	---

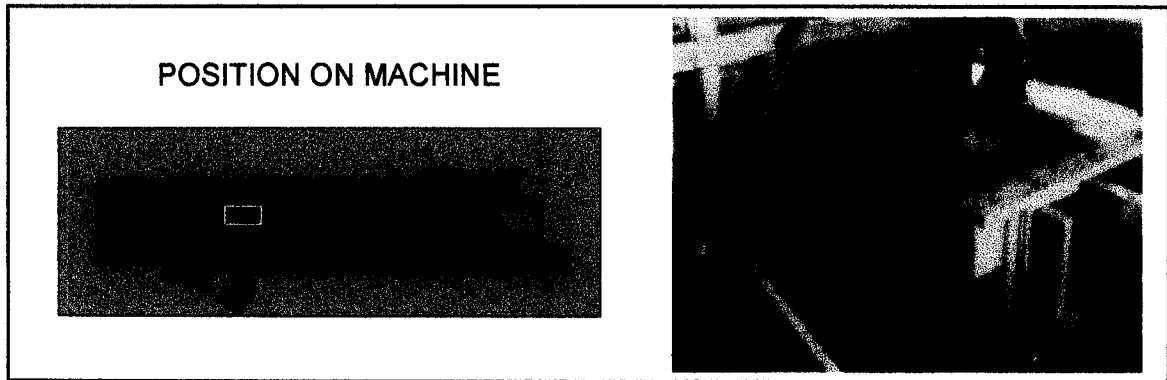

Fig. 20

<p>For Width of Sleeve (Sleeve Back Assembly)</p>	<p>Adjustment is obtained by unclamping the pinlocks situated on the opposite side to the product infeed of the machine sliding them to suit the sleeve width, and then re-clamping the pinlocks into position creating a guide for the back of the sleeves, this avoids the product passing straight through the sleeve. (Fig. 21)</p>
---	---

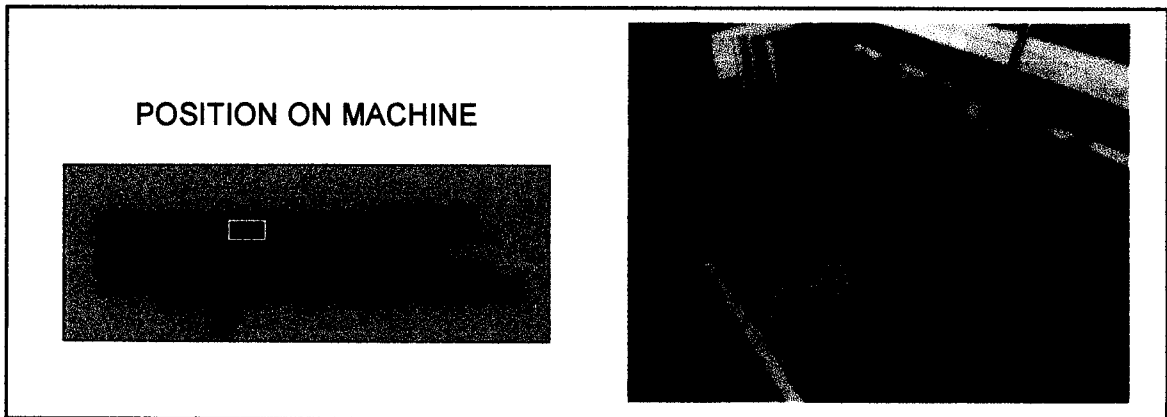

Fig. 21

### **3.B.1. Sleever Change Procedures Continued**

Overhead Extensions	Adjustment is obtained by undoing the locking screws and setting to the required position by sliding the extension forward or back. (Fig. 22)
---------------------	---

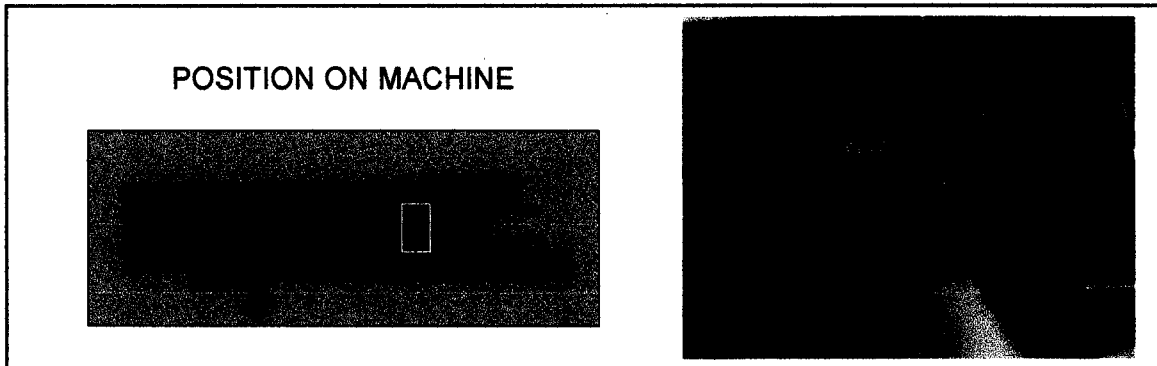

Fig. 22

### **3.B.2. Rotary Sleeve Feeder Change**

Magazine Width	Undoing the pinlocks situated on the magazine slides and adjusting to the required size make adjustment for sleeves. First set the sleeve crease to the edge of the fixed platen and adjust the other side to suit the full sleeve width. The magazine should be just loose enough to let the sleeve stack slide down through the magazine with ease. (Fig. 23) Set to pinlock setting if provided.
----------------	---

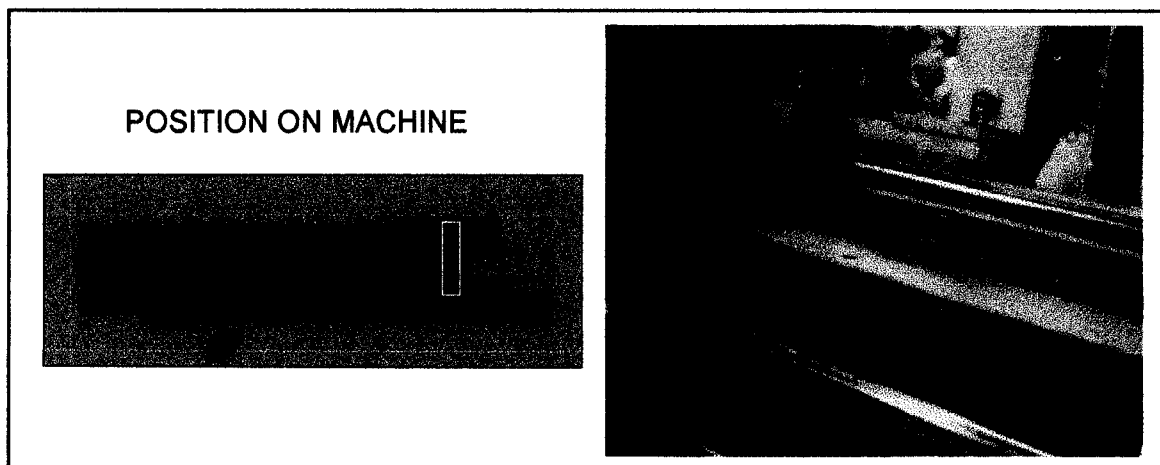
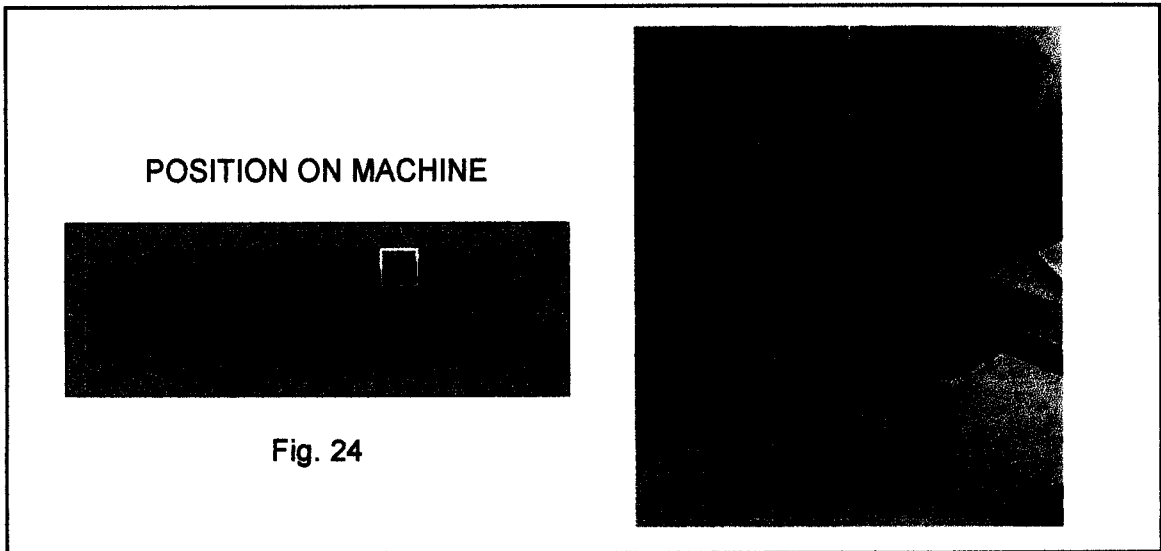

Fig. 23

### 3.B.2. Rotary Sleeve Feeder Change Continued

<p><b>Rotary Sleeve Height</b></p>	<p>Raising or lowering the rotary head, which will adjust the height of the suction cups to the sleeve, obtains adjustment of the sleeve height. This is achieved by turning the hand wheel and winding the rotary up or down to give the required readout. To ensure correct sleeve placement onto the platen, make sure that when the arms are in the vertical position the bucket are correctly positioned on the timing mark to receive the sleeves. (Fig. 24 and 25)</p>
------------------------------------	---



<p><b>Rotary Sleeve Height continued</b></p>	<p>Subject to size and quality of sleeves, when the suction cups are in the vertical position, the edge of the cup facing the bucket should be approximately 10mm away from the timing mark. (Fig. 34)</p>
--	--

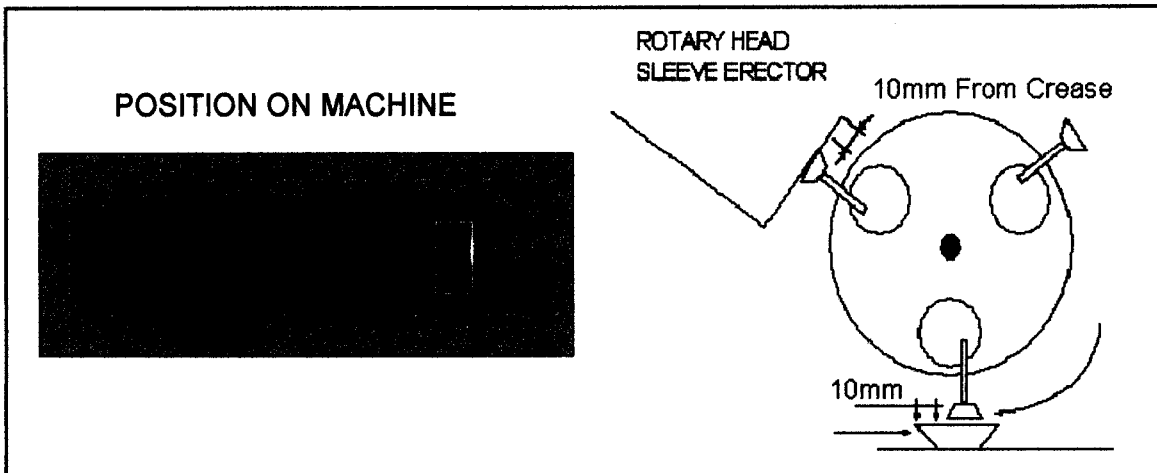
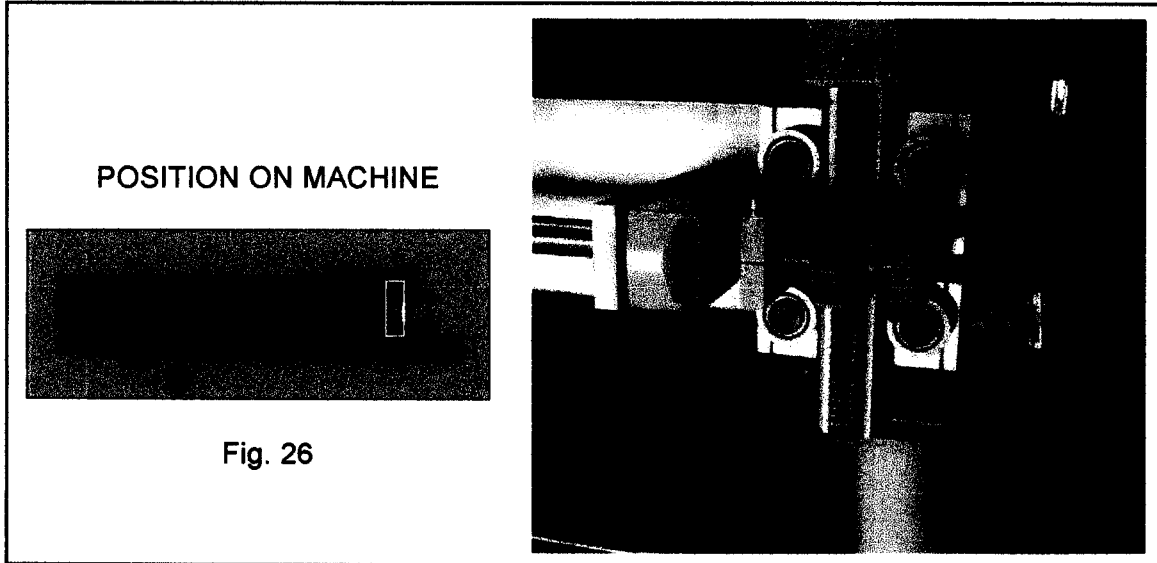

Fig. 25

### **3.B.2. Rotary Sleeve Feeder Change Continued**

<p><b>Magazine Height</b></p>	<p>Firstly, position suction cups so that they 'squarely' touch the sleeves in the magazine. By using a spanner on the adjuster situated beneath the magazine turn to achieve the position of the cup edge from the crease line on the sleeve. (Fig. 26)</p>
-------------------------------	--



<p><b>Magazine Height Continued</b></p>	<p>Adjustment of the suction cups should now be made to suit the width of the sleeve. Undoing the pinlocks situated on the suction cup holder and moving to the correct position achieve this. Ensure that suction cups miss the main chain buckets during the operation.</p>
---	---

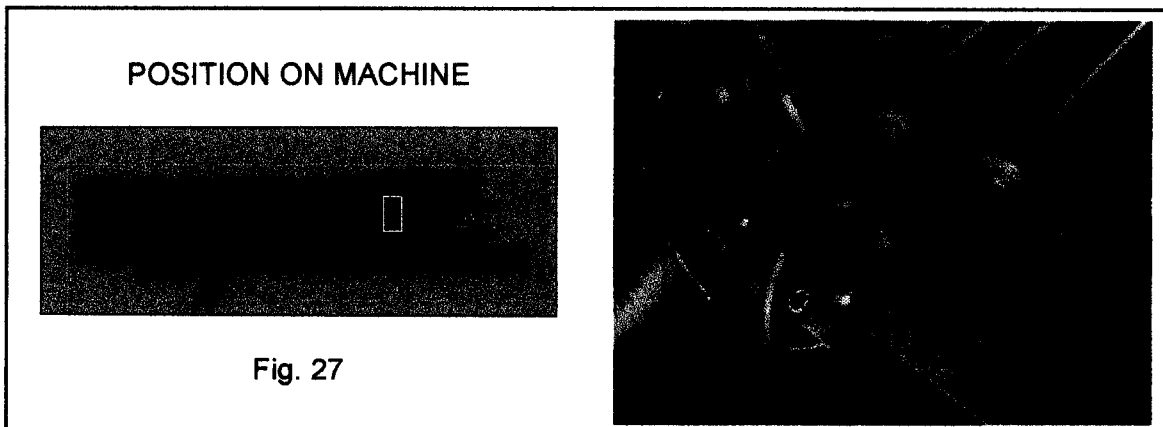

### **3.B.2. Rotary Sleeve Feeder Change Continued**

<p><b>Magazine Height Continued</b></p>	<p>Finally, set the top Sleeve Rail to the required height by undoing the locking handles and positioning accordingly and if required adjust the ledges to suit, approximately 5-10mm. (See Fig. 28)</p>
---	--

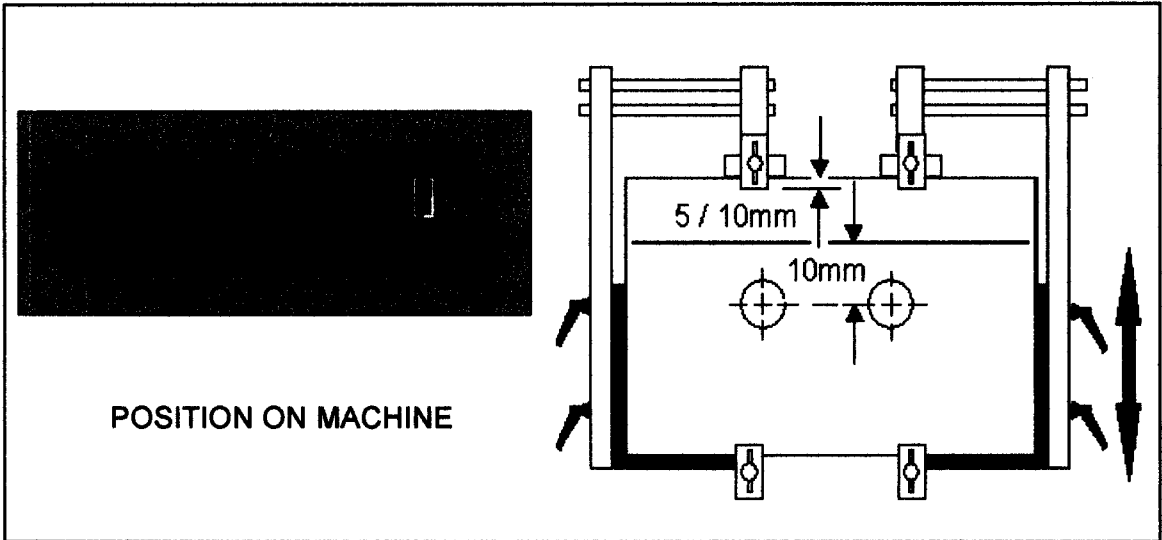

Fig. 28



### Grade Change Procedures

1. Move top ski infeed side **A**
2. Move magazine width infeed side **B**
3. Move top ski drive side. **C**
4. Move magazine width on the Drive Side **D**
5. Move the magazine height and lock using 5mm allen key **E**
6. Move rotary tilt **F**
7. Move Vacuum Timing Disc **G**

• **Please note:** - Items 1 through to 7 may require changing in reverse depending on change combination.

8. Suckers on infeed side (*Does not move on current carton combinations*). **H**
9. Suckers on drive side. **I**
10. Bullnose on overhead rail. **J**
11. Adjust overhead height and lock using 5mm allen key. **K**
12. Adjust position of overhead rail rotary end. **L**
13. Adjust position of overhead rail outfeed end. **M**
14. Adjust position of back stop to suit carton width. **N**
15. Adjust position of outfeed side plate to suit carton width. **O**

**Pinlock Configuration:**

<b>Colour Code:</b>	<b>Carton Size:</b>	<b>Description:</b>
<b>Red</b>	<b>88/116 x 50 x 80</b>	
<b>Yellow</b>	<b>88/116 x 55 x 80</b>	



# Recommended Spares List

M/C Type

S11  
Pre-Glued Sleever

M/C Serial No.

02-155

Sheet No.

1 OF 1

M/C No.	Description	Qty	Price
ELO053	CONTACTOR	1	£20.60 Each
ELO003	RELAY	3	£6.92 Each
ELO012	SIPHA SWITCH	1	£115.44 Each
ELO014	SAFETY SWITCH	2	£42.04 Each
ELO213	PHOTOCELL	1	£90.00 Each
ELO007	PROXIMITY SENSOR	1	£43.12 Each
ELO017	ROLLER LEVER SWITCH BODY (CLUTCH)	1	£20.08 Each
ELO015	ROLLER LEVER SWITCH HEAD (CLUTCH)	1	£17.96 Each
ELO045	6A MINATURE CIRCUIT BREAKER	1	£10.80 Each
ELO163	SPEED POT	1	£11.20 Each
ME0168	ENDLESS CONVEYOR BELT 7090mm x 250mm	1	£146.42 Each
ME0027	20mm SELF/LUBE FLANGE BEARING	2	£13.90 Each
ME0042	BEARING 6004-2Z	8	£3.00 Each
MI0010	INDEX PLUNGER KNOB (PINLOCK)	6	£7.70 Each
MI0015	30mm DIA. M8 BLACK KNOB	3	£0.84 Each
ME0039	BEARING 6002-2Z	2	£3.16 Each
ME0164	SPZ WEDGE BELT OUTFEED DRIVE	2	£10.50 Each
PN0070	SOLENOID VALVE (AGITATORS)	1	£53.78 Each
PN0077	SOLENOID CABLE AND PLUG	1	£15.00 Each
PN0127	SMC ROTARY ACTUATOR	1	£167.84 Each
PN0003	FLOW REGULATOR	4	£11.06 Each
PN0131	VACUUM GENERATOR	1	£56.00 Each
PN0068	SOLENOID VALVE (VACUUM SECTION)	1	£49.30 Each
PN0078	SOLENOID CABLE AND PLUG	1	£15.02 Each
PN0043	SUCTION CUPS	4	£8.50 Each
ME0125	OPTI-TORQUE CLUTCH SIZE 2	1	£312.18 Each
ME0060	BEVEL GEARBOX 3 SHAFTS 1 : 1 RATIO	1	£381.96 Each
ME0031	30mm S/LUBE FLANGE BEARING	2	£19.42 Each
FR0553	LINEAR RAIL	2	£56.20 Each
ME0049	LINEAR SLIDE CARRIAGE	2	£71.92 Each
ME0119	6005-2Z BEARING	2	£3.78 Each
ME0041	6004-2RS BEARING	4	£4.16 Each
ME0028	25mm S/LUBE PILLAR BLOCK BEARING	2	£15.00 Each
ME0032	624-2Z BEARING	6	£3.30 Each
ME0040	6003-2Z BEARING	2	£3.30 Each
ME0061	COUNTER	1	£46.28 Each
MI0009	MAGNETIC CATCH	2	£2.94 Each
MI0029	V/PRESSURE GAS STRUT 100mm STROKE	1	£40.68 Each
MI0031	V/PRESSURE GAS STRUT 200mm STROKE	1	£79.30 Each
MI0006	IVORY ACETAL HINGES	3	£11.04 Each
	<b>BUCKETS</b> (TO SUIT PINLOCK COLOURS)		
TFIB 0001	INTERMEDIATE BUCKET (RED & YELLOW)	1	£38.00 Each



COMPONENT PARTS LIST		CUSTOMER		STOCK MACHINE			M/C SERIAL No.	03-155
ASSEMBLY DRG. No.		TITLE	PNEUMATIC BILL OF PARTS		ISSUED BY		JPS	
155-PN-900		DATE	03/03/2003	M/C TYPE	PRE-GLUED SEMI SLEEVE			
REF No.	PART/DRG No.	DESCRIPTION	No. OFF	PRODUCT I.D. No	P/O	SUPPLIER		
1		FLOW REGULATOR	4	PN0003				
2		STUD FITTING	2	PN0006				
3		FEMALE STUD FITTING	1	PN0009				
4		SWIVEL ELBOW	4	PN0011				
5		TEE FITTING	2	PN0019				
6		SWIVEL ELBOW	6	PN0021				
7		Y PIECE FITTING	1	PN0023				
8		STUD FITTING	3	PN0024				
9		SWIVEL ELBOW	2	PN0025				
10		TEE FITTING	1	PN0028				
11		Y PIECE FITTING	1	PN0029				
12		BRASS SILENCER	2	PN0036				
13		1/8 MALE - 1/4 FEMALE ADAPTOR	4	PN0041				
14		SUCTION CUPS	4	PN0043				
15		NIPPLE FITTING	1	PN0047				
16		FILTER REGULATOR C/W GUAGE	1	PN0057				

		COMPONENT PARTS LIST		CUSTOMER		STOCK MACHINE				M/C SERIAL No.	03-155	
		ASSEMBLY DRG. No.		TITLE		PNEUMATIC BILL OF PARTS		P/O		ISSUED BY		JPS
		155-PN-900		DATE		03/03/2003		M/C TYPE		PRE-GLUED SEMI SLEEVE		
REF No.	PART/DRG No.	DESCRIPTION		No. OFF	PRODUCT I.D. No	P/O	SUPPLIER					
17		REGULATOR MOUNTING BRACKET		1	PN0141							
18		VACUUM GUAGE		1	PN0065							
19		SOLENOID VALVE (VACUUM SELECTION)		1	PN0068							
20		SOLENOID VALVE (AGITATORS)		1	PN0070							
21		SOLENOID CABLE & PLUG		1	PN0077							
22		SOLENOID CABLE & PLUG		1	PN0078							
23		SWIVEL TEE FITTING		2	PN0121							
24		1/4 - 6 LOW PROFILE SWIVEL ELBOW		2	PN0122							
25		SMC ROTARY ACTUATOR		2	PN0127							
26		VACUUM GENERATORS		2	PN0131							
27		VACUUM GENERATOR SPACERS		4	FR0715							
28		BRASS SILENCER		1	PN0037							
29		1/4 BSP BLANKING PLUG		2	PN0039							
30												





# SPEED DISPLAY PCB

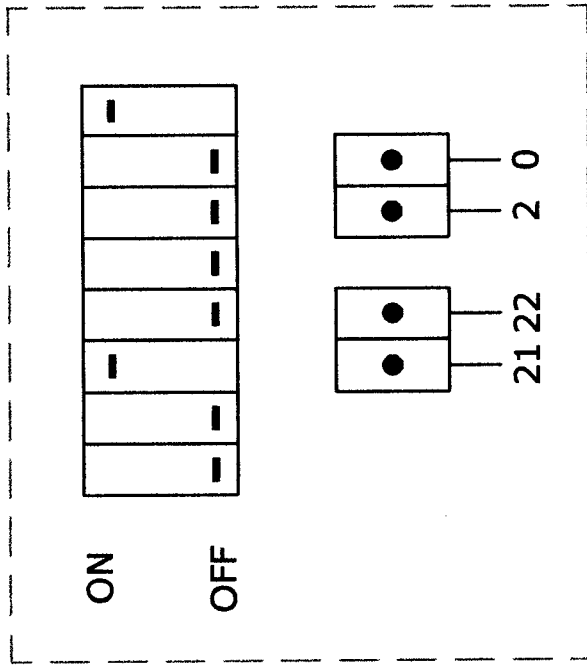

E	0	0	2	7	8	9	16	21	22	B	W	R	†	S	6	2	S	S	3	S	4	1	R	S	2	E	N	D	S	T	O	P
---	---	---	---	---	---	---	----	----	----	---	---	---	---	---	---	---	---	---	---	---	---	---	---	---	---	---	---	---	---	---	---	---

# DIP SWITCH

0.	ISSUED FOR APPROVAL.	MW	07/04/03	Drawn	Date	Chk'd
Drawn By:	M. WINFIELD	Chk'd By:	M. WINFIELD	Scale:	N.T.S	
Date:	07/04/03	Date:	07/04/03	Sheet:	1 OF 1.	
Title:	TERMINATION DRAWING S11 PRE-GLUED SLEEVE WITH SPEED DISPLAY					
Qty Req:	155-EL-900-03					
Rev:	0.					

**FREEMANTLE**  
 T. Freemantle Limited  
 13 Atkinson Way,  
 Foshills Industrial Estate,  
 Southorpe DN15 8QJ

T: ++44(0) 1724 278908  
 F: ++44(0) 1724 278909

THIS DRAWING IS SUBJECT TO COPYRIGHT RULES  
 Limits Not Stated +/- 0.25mm

Notes:	Mating Parts:		Materials List	
	Item	Qty.	Description	Material
— = BREAK				

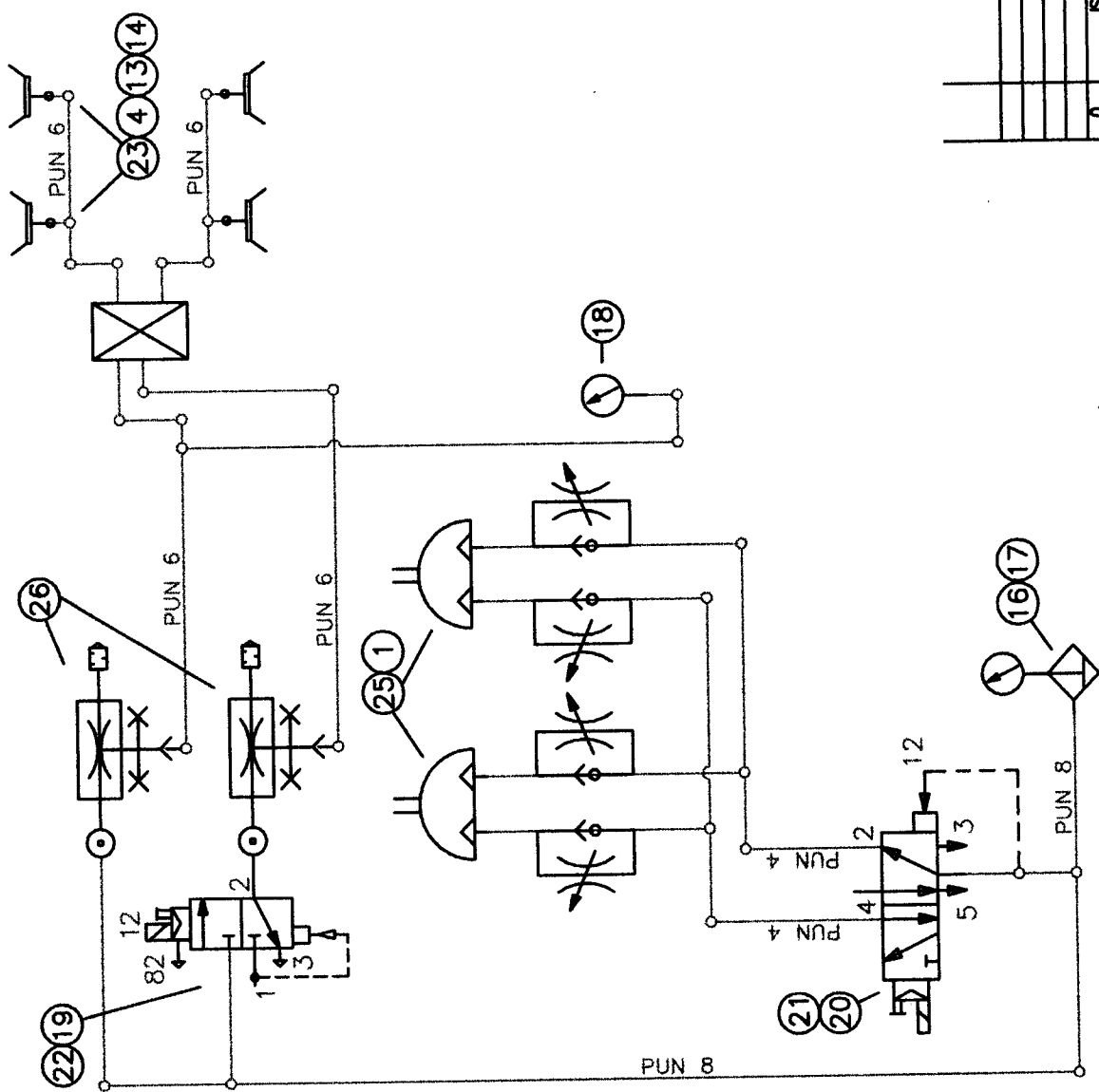

Notes:  
PLEASE REFER TO PNEUMATIC COMPONENTS LIST

**FREEMANTLE**  
T. Freemantle Limited  
13 Atkinson Way,  
Foshill Industrial Estate,  
Scunthorpe DN15 8QJ  
T: +44(0) 1724 276908  
F: +44(0) 1724 276909

THIS DOCUMENT AND ALL THE INFORMATION IS THE SOLE PROPERTY OF T. FREEMANTLE LIMITED AND IS CONFIDENTIAL AND MUST NOT BE MADE PUBLIC, REPRODUCED OR GIVEN TO A THIRD PARTY UNLESS WRITTEN PERMISSION HAS BEEN OBTAINED FROM T. FREEMANTLE LIMITED.  
THIS DRAWING IS ALSO SUBJECT TO RETURN UPON DEMAND BY T. FREEMANTLE LIMITED.  
THIS DRAWING IS SUBJECT TO COPYRIGHT RULES  
Limits Not Stated +/- 0.25mm

Rev.	0	ISSUED FOR MANUFACTURE.	Drawn	MW	Date	03/03/03	Chk'd		
Drawn By:	M. WINFIELD	Chk'd By:					Scale:	N.T.S	
Date:	03/03/03	Date:					Sheet:	1 OF 1	
Title: S11 SEMI AUTOMATIC SLEEVE PNEUMATIC SCHEMATIC									
Drwg No:	155-PN-900-01							Rev:	0.